

# TAN AIR PNEUMATICS

## TPCM2 J.I.S TYPE CYLINDER

### F TYPE FRONT FLANGE

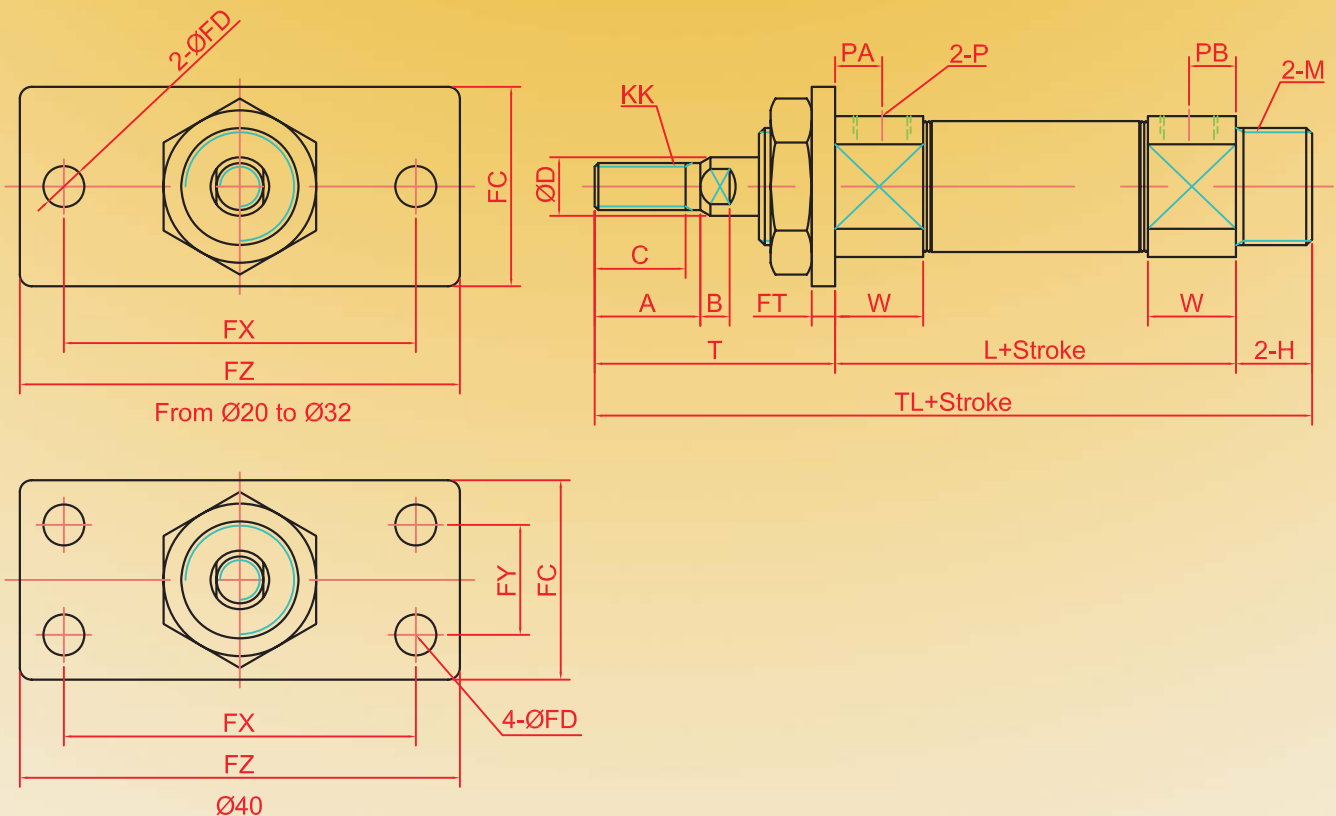

BORE	STROKE RANGE	C	A	B	D	H	KK	L	M	P(PT)	PA	PB	T
20	-300	15.5	18	5.0	10	13	M8*1.25	62	M20*1.5	1/8	8	8	41
25	-300	19.5	22	5.5	12	13	M10*1.25	62	M26*1.5	1/8	8	8	45
32	-300	19.5	22	5.5	12	13	M10*1.25	64	M26*1.5	1/8	8	8	45
40	-300	21.0	24	7.5	16	16	M14*1.25	88	M30*2.0	1/4	11	11	50
BORE	STROKE RANGE	TL	W	FC	FD	FT	FX	FY	FZ				
20	-300	116	15	34	7	4	60	-	75				
25	-300	120	15	40	7	4	60	-	75				
32	-300	122	15	40	7	4	60	-	75				
40	-300	154	21	52	7	5	66	36	82				

# TAN AIR PNEUMATICS

## TPCM2 J.I.S TYPE CYLINDER

### F TYPE REAR FLANGE

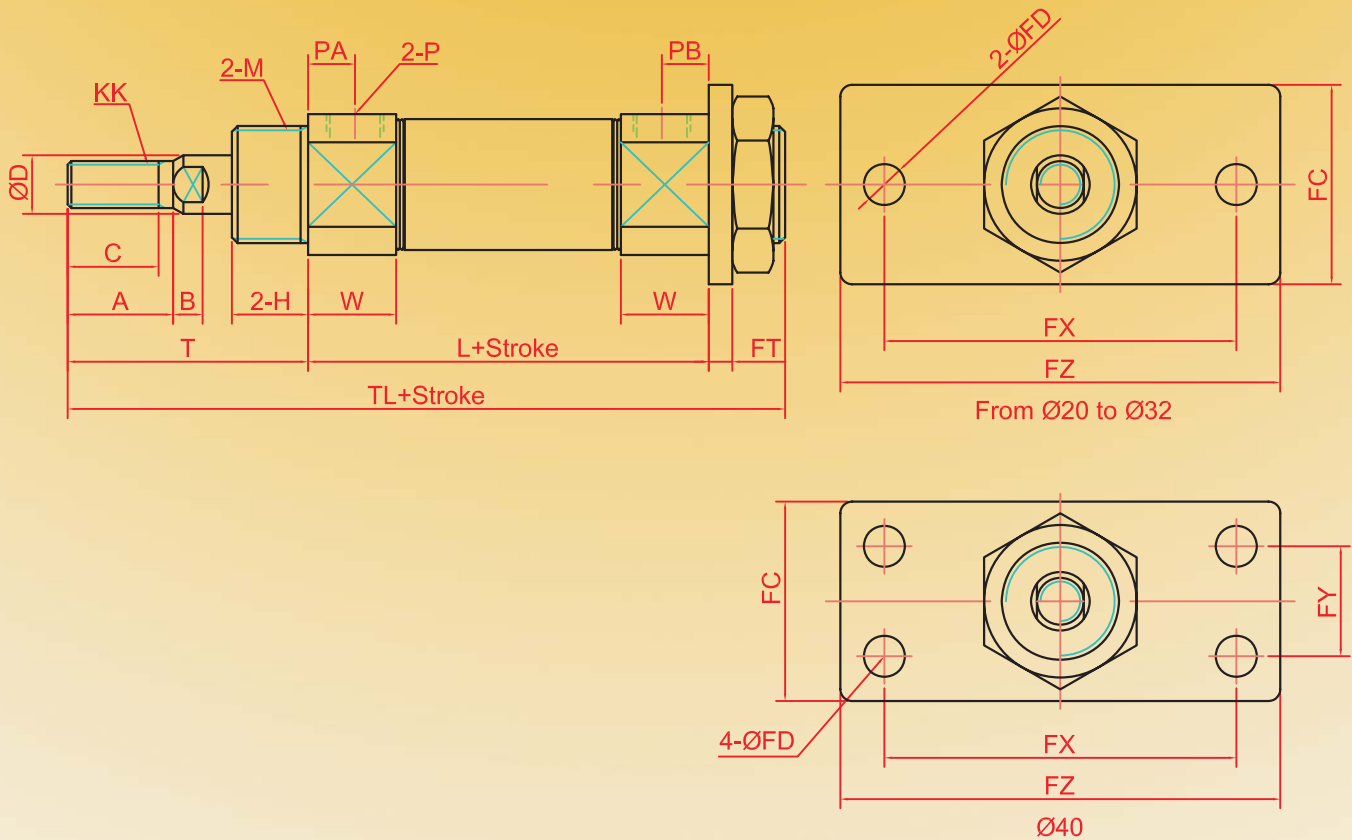

BORE	STROKE RANGE	C	A	B	D	H	KK	L	M	P(PT)	PA	PB	T
20	-300	15.5	18	5.0	10	13	M8*1.25	62	M20*1.5	1/8	8	8	41
25	-300	19.5	22	5.5	12	13	M10*1.25	62	M26*1.5	1/8	8	8	45
32	-300	19.5	22	5.5	12	13	M10*1.25	64	M26*1.5	1/8	8	8	45
40	-300	21.0	24	7.5	16	16	M14*1.25	88	M30*2.0	1/4	11	11	50
BORE	STROKE RANGE	TL	W	FC	FD	FT	FX	FY	FZ				
20	-300	116	15	34	7	4	60	-	75				
25	-300	120	15	40	7	4	60	-	75				
32	-300	122	15	40	7	4	60	-	75				
40	-300	154	21	52	7	5	66	36	82				

# TAN AIR PNEUMATICS

## TPCM2 J.I.S TYPE CYLINDER

### L TYPE FOOT MOUNT

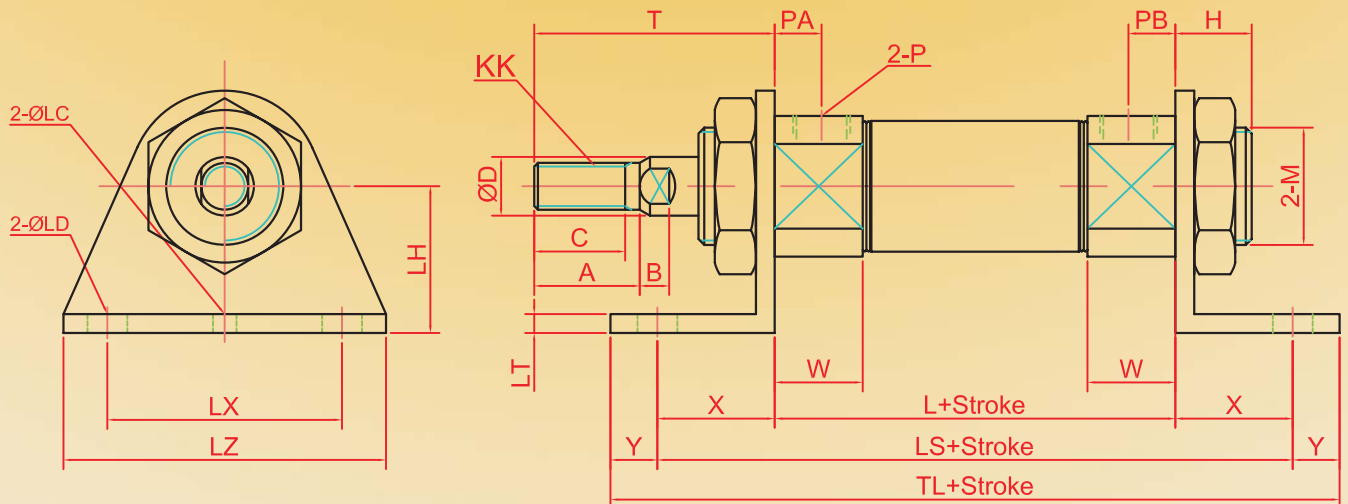

BORE	STROKE RANGE	C	A	B	D	H	KK	L	M	P(PT)	PA	PB	LC
20	-400	15.5	18	5.0	10	13	M8*1.25	62	M20*1.5	1/8	8	8	4
25	-450	19.5	22	5.5	12	13	M10*1.25	62	M26*1.5	1/8	8	8	4
32	-450	19.5	22	5.5	12	13	M10*1.25	64	M26*1.5	1/8	8	8	4
40	-500	21.0	24	7.5	16	16	M14*1.25	88	M30*2.0	1/4	11	11	4
BORE	STROKE RANGE	LD	LH	LS	LT	LX	LZ	T	TL	W	X	Y	
20	-400	6.8	25	102	3.2	40	55	41	116	15	20	8	
25	-450	6.8	28	102	3.2	40	55	45	120	15	20	8	
32	-450	6.8	28	104	3.2	40	55	45	122	15	20	8	
40	-500	7.0	30	134	3.2	55	75	50	154	21	23	13	

# TAN AIR PNEUMATICS

## TPCM2 J.I.S TYPE CYLINDER

### C TYPE SINGLE REAR CLEVIS

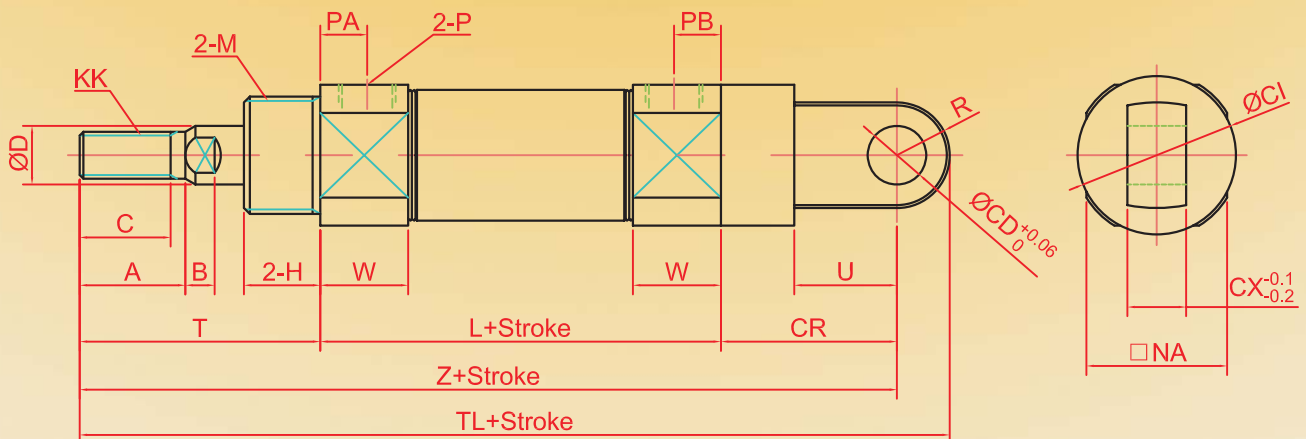

BORE	STROKE RANGE	C	A	B	CI	CD	CR	CX	D	H	KK	L	M
20	-400	15.5	18	5.0	27	9	30	10	10	13	M8*1.25	62	M20*1.5
25	-450	19.5	22	5.5	33	9	30	10	12	13	M10*1.25	62	M26*1.5
32	-450	19.5	22	5.5	37.5	9	30	10	12	13	M10*1.25	64	M26*1.5
40	-500	21.0	24	7.5	46.5	10	90	15	16	16	M14*1.25	88	M30*2.0
BORE	STROKE RANGE	P(PT)	PA	PB	R	T	TL	U	NA	W	Z		
20	-400	1/8	8	8	9	41	142	14	24	15	133		
25	-450	1/8	8	8	9	45	146	14	30	15	137		
32	-450	1/8	8	8	9	45	148	14	34.5	15	139		
40	-500	1/4	11	11	11	50	188	18	42.5	21	177		

# TAN AIR PNEUMATICS

## TPCM2 J.I.S TYPE CYLINDER

### D TYPE DOUBLE REAR CLEVIS

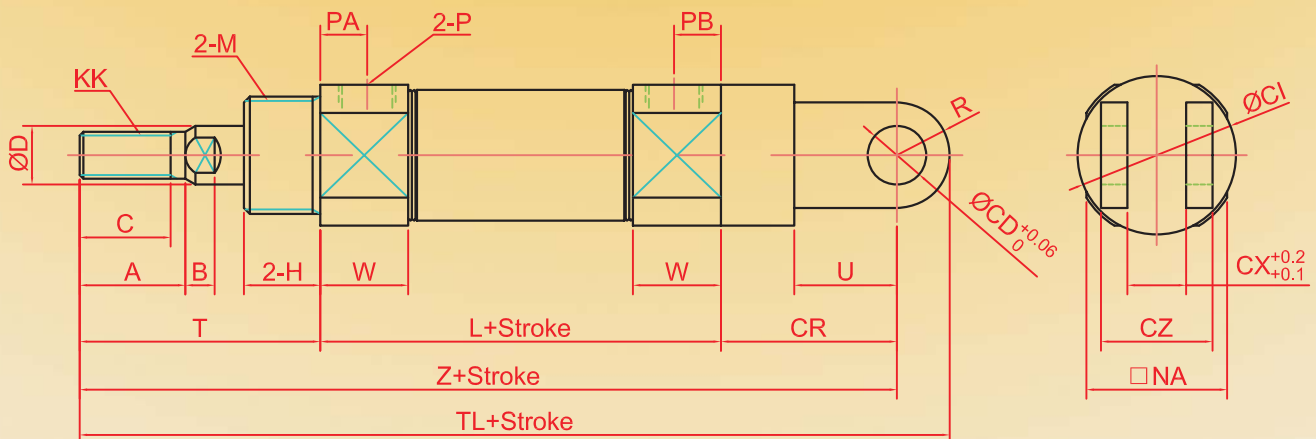

BORE	STROKE RANGE	C	A	B	CI	CD	CR	CX	D	H	KK	L	M
20	-400	15.5	18	5.0	27	9	30	10	10	13	M8*1.25	62	M20*1.5
25	-450	19.5	22	5.5	33	9	30	10	12	13	M10*1.25	62	M26*1.5
32	-450	19.5	22	5.5	37.5	9	30	10	12	13	M10*1.25	64	M26*1.5
40	-500	21.0	24	7.5	46.5	10	90	15	16	16	M14*1.25	88	M30*2.0
BORE	STROKE RANGE	P(PT)	PA	PB	R	T	TL	U	NA	W	Z	CZ	
20	-400	1/8	8	8	9	41	142	14	24	15	133	19	
25	-450	1/8	8	8	9	45	146	14	30	15	137	19	
32	-450	1/8	8	8	9	45	148	14	34.5	15	139	19	
40	-500	1/4	11	11	11	50	188	18	42.5	21	177	30	

# TAN AIR PNEUMATICS

## TPCM2 J.I.S TYPE CYLINDER

### T TYPE FRONT TRUNION

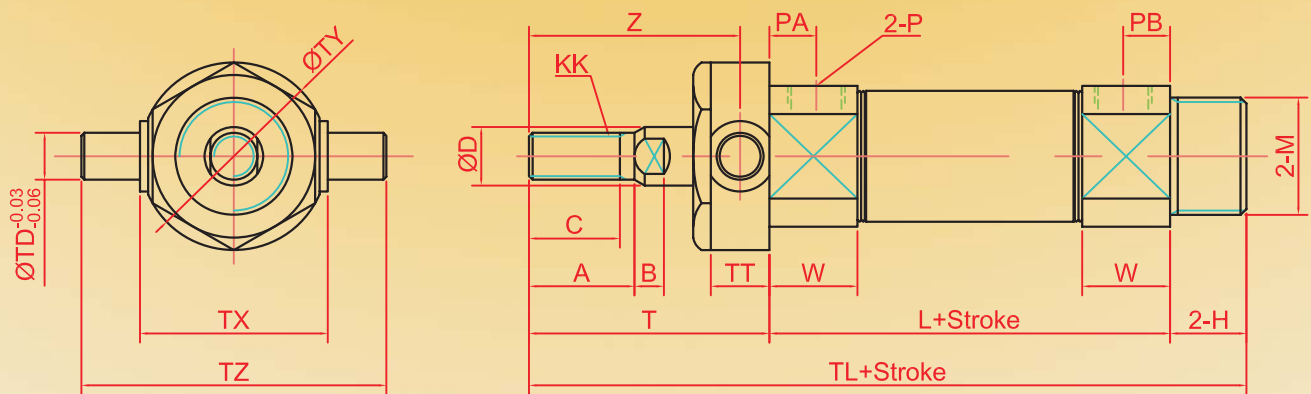

BORE	STROKE RANGE	C	A	B	D	H	KK	L	M	P(PT)	PA	PB
20	-300	15.5	18	5.0	10	13	M8*1.25	62	M20*1.5	1/8	8	8
25	-300	19.5	22	5.5	12	13	M10*1.25	62	M26*1.5	1/8	8	8
32	-300	19.5	22	5.5	12	13	M10*1.25	64	M26*1.5	1/8	8	8
40	-300	21.0	24	7.5	16	16	M14*1.25	88	M30*2.0	1/4	11	11
BORE	STROKE RANGE	T	TD	TL	TT	TX	TY	TZ	W	Z		
20	-300	41	8	116	10	32	32	52	15	36		
25	-300	45	9	120	10	40	40	60	15	40		
32	-300	45	9	122	10	40	40	60	15	40		
40	-300	50	10	154	11	53	53	77	21	44.5		

# TAN AIR PNEUMATICS

## TPCM2 J.I.S TYPE CYLINDER

### T TYPE REAR TRUNION

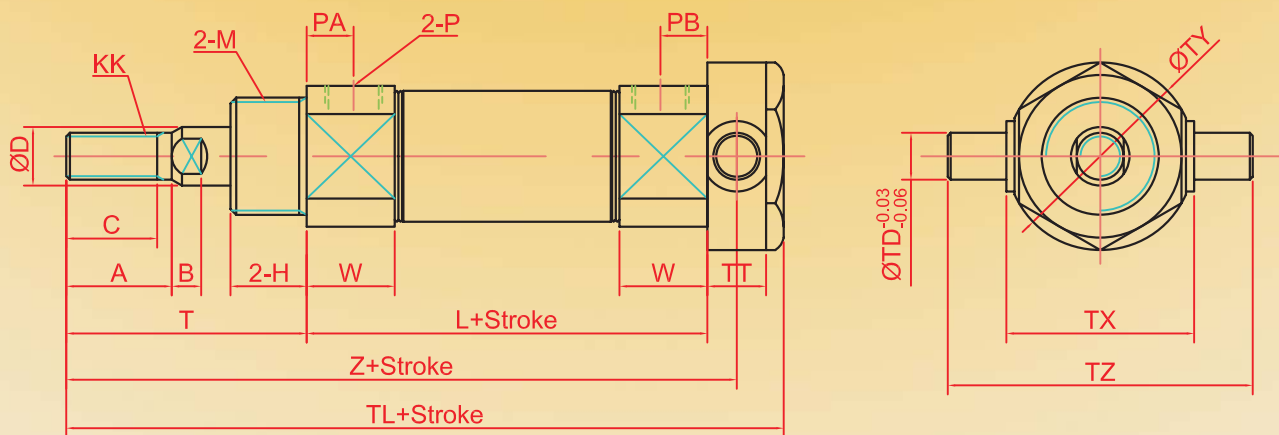

BORE	STROKE RANGE	C	A	B	D	H	KK	L	M	P(PT)	PA	PB
20	-300	15.5	18	5.0	10	13	M8*1.25	62	M20*1.5	1/8	8	8
25	-300	19.5	22	5.5	12	13	M10*1.25	62	M26*1.5	1/8	8	8
32	-300	19.5	22	5.5	12	13	M10*1.25	64	M26*1.5	1/8	8	8
40	-300	21.0	24	7.5	16	16	M14*1.25	88	M30*2.0	1/4	11	11
BORE	STROKE RANGE	T	TD	TL	TT	TX	TZ	W	Z			
20	-300	41	8	116	10	32	52	15	108			
25	-300	45	9	120	10	40	60	15	112			
32	-300	45	9	122	10	40	60	15	114			
40	-300	50	10	154	11	53	77	21	149.5			

# TAN AIR PNEUMATICS

## TPCM2 J.I.S TYPE CYLINDER

I TYPE SINGLE KNUCKLE JOINT

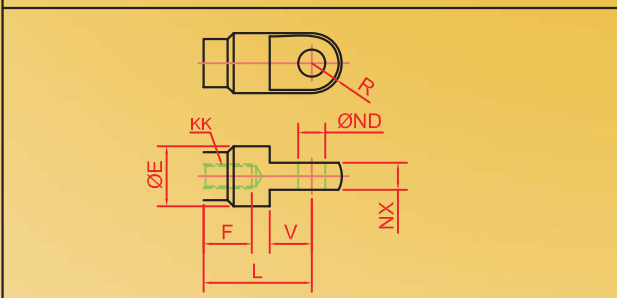

I-D	F	ØE	L	KK	R	V	ØND	NX
20	16	20	36	M8*1.25	10	14	$9^{+0.06}_0$	$9^{+0.1}_{-0.2}$
25,32	18	20	38	M10*1.25	10	14	$9^{+0.06}_0$	$9^{+0.1}_{-0.2}$
40	22	24	55	M14*1.5	15.5	20	$12^{+0.06}_0$	$16^{+0.1}_{-0.3}$

KNUCKLE JOINT PIN

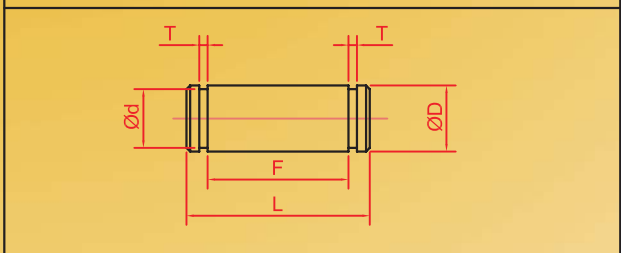

I-D	ØD	Ød	L	F	T	REMARKS
20	$9^{+0.04}_{-0.06}$	8	25	19.2	1.15	
25	$9^{+0.04}_{-0.06}$	8	25	19.2	1.15	
32	$10^{+0.04}_{-0.06}$	9	36.5	30.2	1.3	For Clevis
40	$12^{+0.04}_{-0.06}$	11	44.5	30.8	1.3	For Y Knuckle

Y TYPE DOUBLE KNUCKLE JOINT

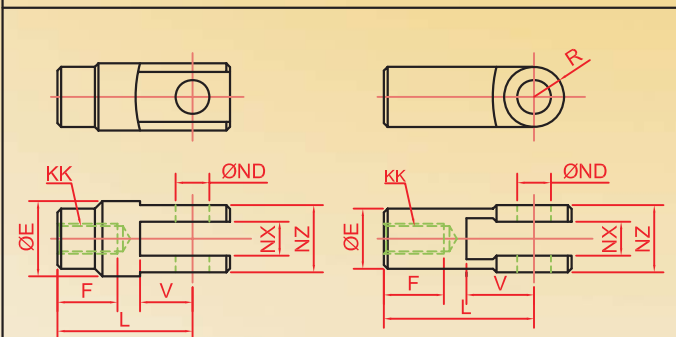

I-D	F	ØE	L	KK	R	V	ØND	NX	NZ
20	16	20	36	M8*1.25	10	14	$9^{+0.06}_0$	$9^{+0.2}_{+0.1}$	18
25,32	18	20	38	M10*1.25	10	14	$9^{+0.06}_0$	$9^{+0.2}_{+0.1}$	18
40	22	24	55	M14*1.5	15.5	20	$12^{+0.06}_0$	$16^{+0.3}_{+0.1}$	38

NOSE MOUNTING NUT

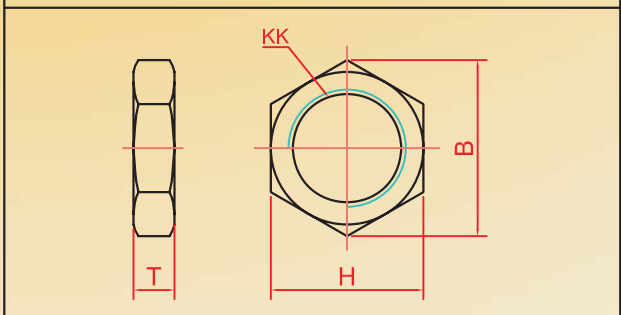

I-D	KK	T	H	B
20	M8*1.25	5	13	15.0
25,32	M10*1.25	6	17	19.6
40	M14*1.5	8	22	25.4

ROD MOUNTING NUT

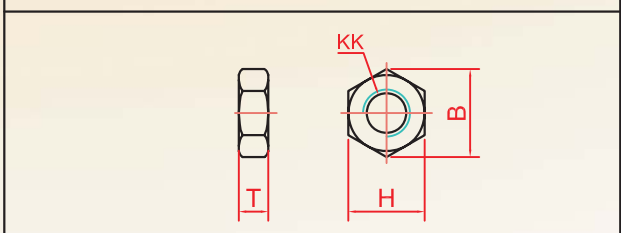

I-D	KK	T	H	B
20	M8*1.25	5	13	15.0
25,32	M10*1.25	6	17	19.6
40	M14*1.5	8	22	25.4