

TANAIR

TPCA2 J.I.S TYPE CYLINDER

BASIC TYPE

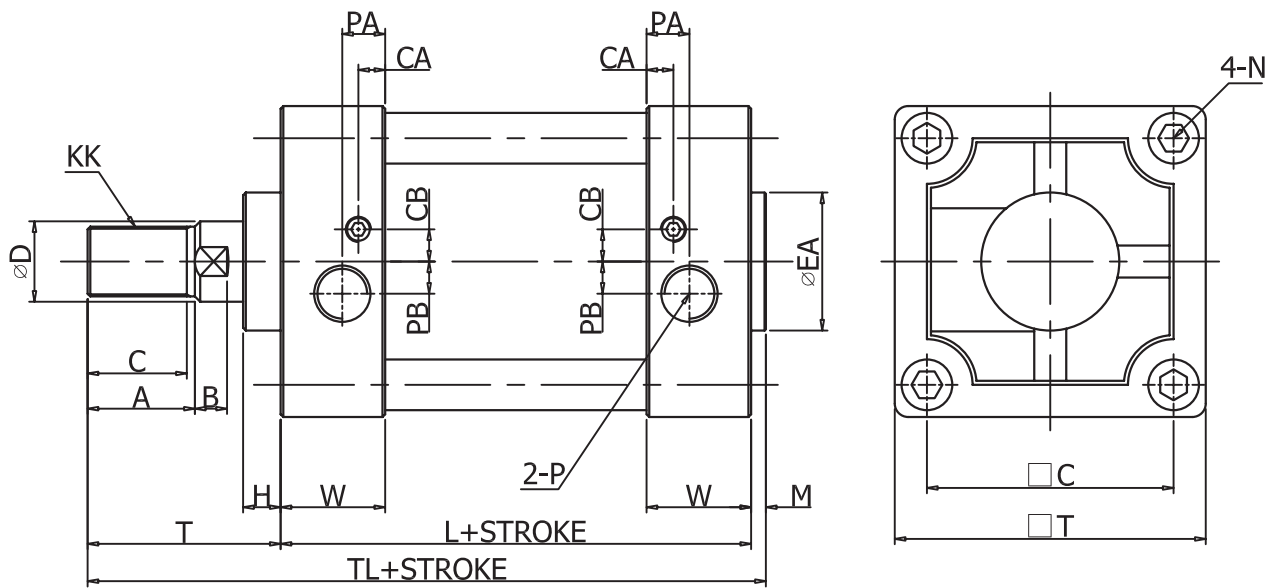

ID(mm)	Stroke Range	C	A	B	□C	$\varnothing D$	P(PT)	$\varnothing EA$	H	KK
40	~500	27	30	8	44	16	1/4	31.5	10	M14X1.5
50	~600	32	35	10	52	20	3/8	39.5	10	M18X1.5
63	~600	32	35	10	64	20	3/8	39.5	10	M18X1.5
80	~800	37	40	12	78	25	1/2	51.5	14	M22X1.5
100	~800	37	40	12	92	30	1/2	51.5	14	M26X1.5

ID(mm)	N	L	CA	CB	PA	PB	□T	T	TL	M	W
40	M8X1.25	84	6	8	11	7	61	51	140.5	5.5	26
50	M8X1.25	90	7.5	10	12	8	70	58	158.5	5.5	27.5
63	M8X1.25	97.5	8	10	13	11.5	83	58	161	5.5	29.5
80	M12X1.75	115.5	10	12	16	12	102	71	192	5.5	36
100	M12X1.75	125.5	10	12	16	12	116	72	203	5.5	39

TAN AIR

TPCA2 J.I.S TYPE CYLINDER

L TYPE FOOT MOUNT

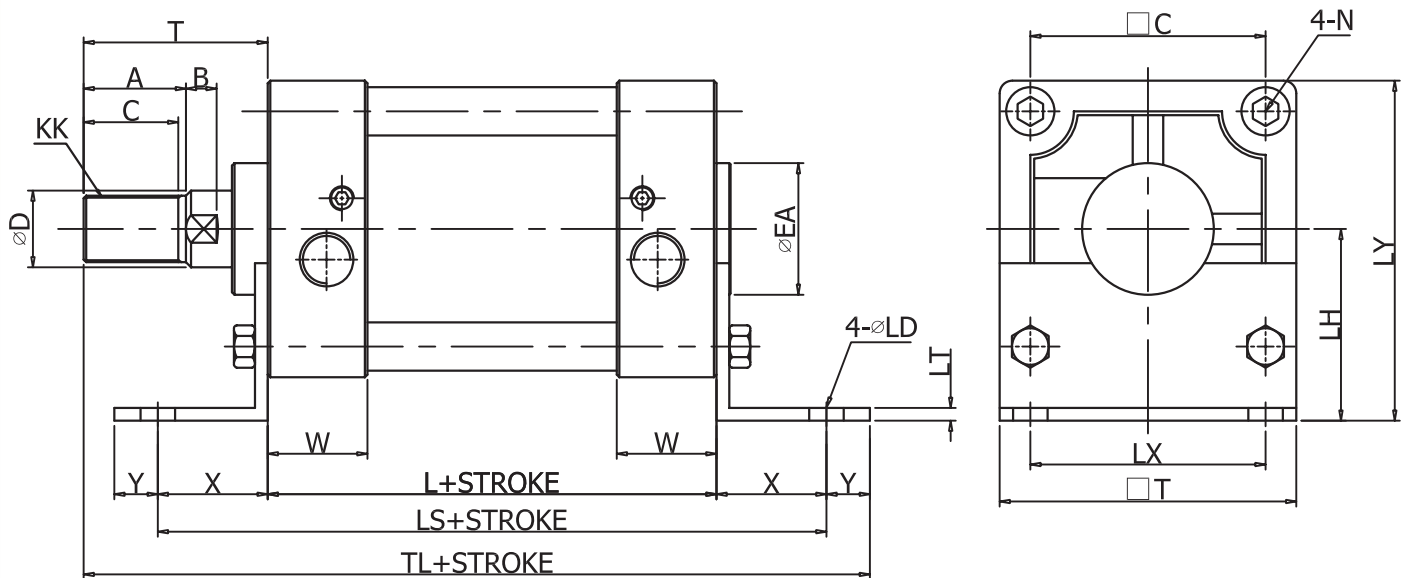

ID(mm)	Stroke Range	C	A	B	□C	∅D	P(PT)	∅EA	H	KK	L
40	~500	27	30	8	44	16	1/4	31.5	10	M14X1.5	84
50	~600	32	35	10	52	20	3/8	39.5	10	M18X1.5	90
63	~600	32	35	10	64	20	3/8	39.5	10	M18X1.5	97.5
80	~800	37	40	12	78	25	1/2	51.5	14	M22X1.5	115.5
100	~800	37	40	12	92	30	1/2	51.5	14	M26X1.5	125.5

ID(mm)	N	∅LD	LH	LS	LT	LX	LY	X	Y	□T	T	TL	W
40	M8X1.25	9.0	40	138	3	42	70	27	13	61	51	175	26
50	M8X1.25	9.0	45	144	3	50	80	27	13	70	58	188	27.5
63	M8X1.25	11.5	50	165.5	3	59	93	34	16	83	58	205.5	29.5
80	M12X1.75	13.5	65	203.5	5	76	116	44	16	102	71	246.5	36
100	M12X1.75	13.5	75	211.5	5	92	133	43	17	116	72	257.5	39

TAN AIR

TPCA2 J.I.S TYPE CYLINDER

F TYPE FRONT FLANGE

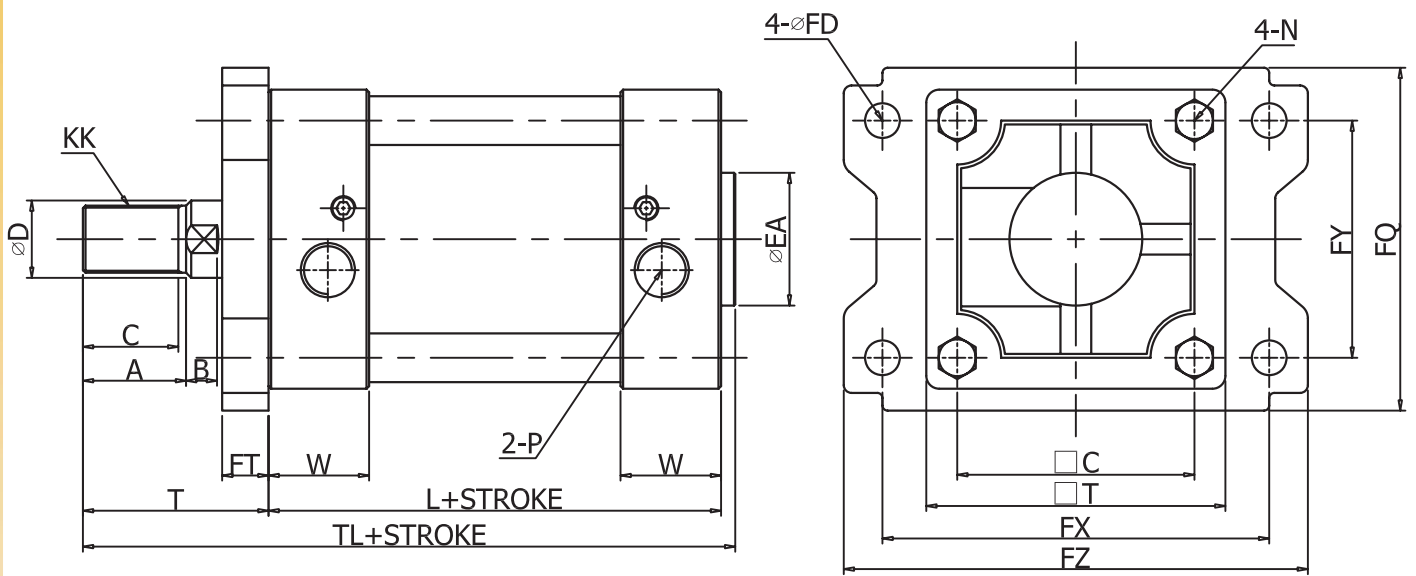

ID(mm)	Stroke Range	C	A	B	□C	∅D	P(PT)	∅EA	L	KK
40	~500	27	30	8	44	16	1/4	31.5	84	M14X1.5
50	~600	32	35	10	52	20	3/8	39.5	90	M18X1.5
63	~600	32	35	10	64	20	3/8	39.5	97.5	M18X1.5
80	~800	37	40	12	78	25	1/2	51.5	115.5	M22X1.5
100	~800	37	40	12	92	30	1/2	51.5	125.5	M26X1.5

ID(mm)	N	∅FD	FQ	FT	FX	FY	□T	T	TL	FZ	W
40	M8X1.25	9	71	12	80	42	61	51	140.5	100	26
50	M8X1.25	9	81	12	90	50	70	58	158.5	110	27.5
63	M8X1.25	11.5	101	15	105	59	83	58	161	130	29.5
80	M12X1.75	13.5	119	18	130	76	102	71	192	160	36
100	M12X1.75	13.5	133	18	150	92	116	72	203	180	39

TANAIR

TPCA2 J.I.S TYPE CYLINDER

G TYPE REAR FLANGE

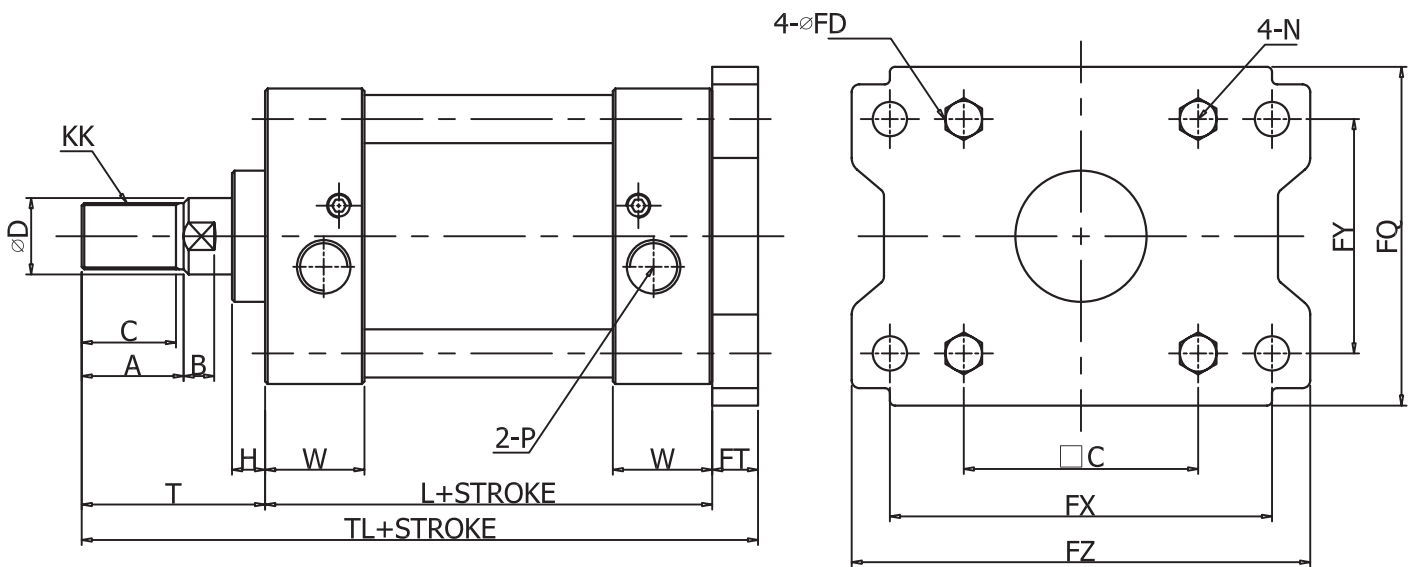

ID(mm)	Stroke Range	C	A	B	□C	ØD	P(PT)	ØEA	L	KK
40	~500	27	30	8	44	16	1/4	31.5	84	M14X1.5
50	~600	32	35	10	52	20	3/8	39.5	90	M18X1.5
63	~600	32	35	10	64	20	3/8	39.5	97.5	M18X1.5
80	~800	37	40	12	78	25	1/2	51.5	115.5	M22X1.5
100	~800	37	40	12	92	30	1/2	51.5	125.5	M26X1.5

ID(mm)	N	H	ΦFD	FQ	FT	FX	FY	□T	T	TL	FZ	W
40	M8X1.25	10	9	71	12	80	42	61	51	147	100	26
50	M8X1.25	10	9	81	12	90	50	70	58	160	110	27.5
63	M8X1.25	10	11.5	101	15	105	59	83	58	170.5	130	29.5
80	M12X1.75	14	13.5	119	18	130	76	102	71	204.5	160	36
100	M12X1.75	14	13.5	133	18	150	92	116	72	215.5	180	39

TAN AIR

TPCA2 J.I.S TYPE CYLINDER

C TYPE SINGLE REAR CLEVIS

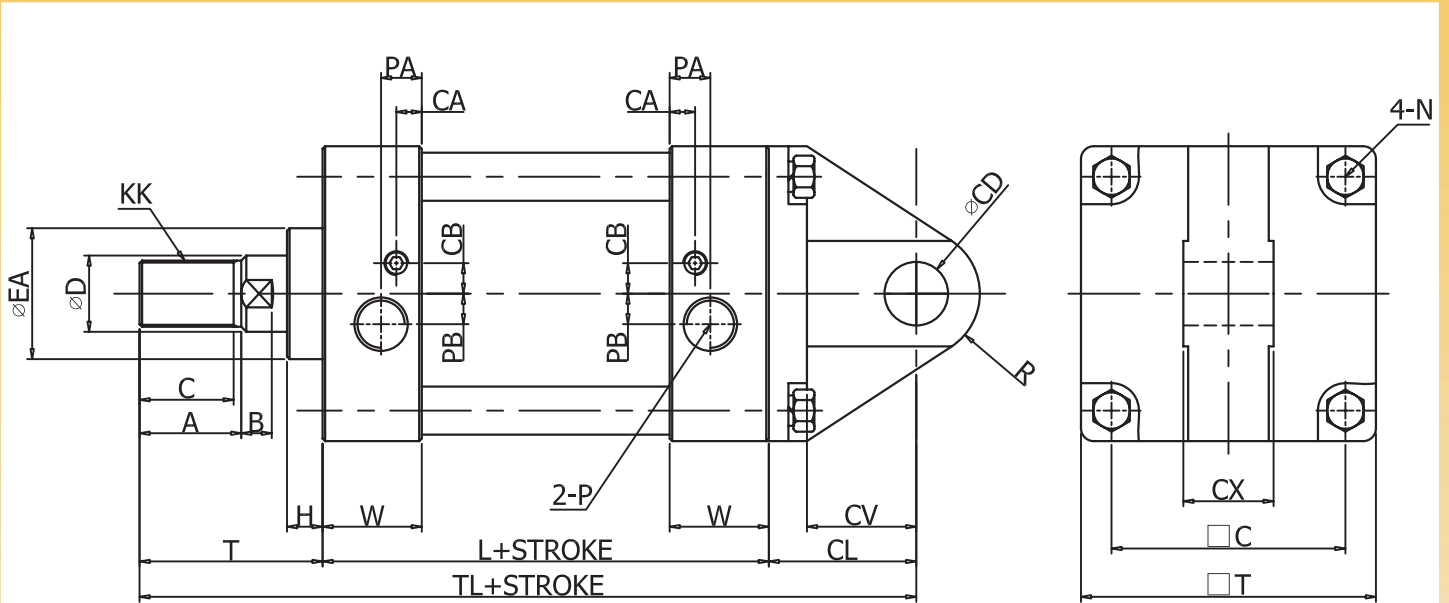

ID(mm)	Stroke Range	C	A	B	□C	ØD	P(PT)	ØEA	H	KK
40	~500	27	30	8	44	16	1/4	31.5	10	M14X1.5
50	~600	32	35	10	52	20	3/8	39.5	10	M18X1.5
63	~600	32	35	10	64	20	3/8	39.5	10	M18X1.5
80	~800	37	40	12	78	25	1/2	51.5	14	M22X1.5
100	~800	37	40	12	92	30	1/2	51.5	14	M26X1.5

ID(mm)	N	L	ΦCD	CL	CV	CX	R	□T	T	TL	W
40	M8X1.25	84	10 ^{+0.055} ₀	30	18	15 ^{-0.1} _{-0.3}	10	61	51	165	26
50	M8X1.25	90	12 ^{+0.070} ₀	35	23	12 ^{-0.1} _{-0.3}	12	70	58	183	27.5
63	M8X1.25	97.5	16 ^{+0.070} ₀	40	27	16 ^{-0.1} _{-0.3}	16	83	58	195.5	29.5
80	M12X1.75	115.5	20 ^{+0.085} ₀	48	34	20 ^{-0.1} _{-0.3}	20	102	71	234.5	36
100	M12X1.75	125.5	25 ^{+0.085} ₀	58	43	25 ^{-0.1} _{-0.3}	25	116	72	255.5	39

TAN AIR

TPCA2 J.I.S TYPE CYLINDER

D TYPE DOUBLE REAR CLEVIS

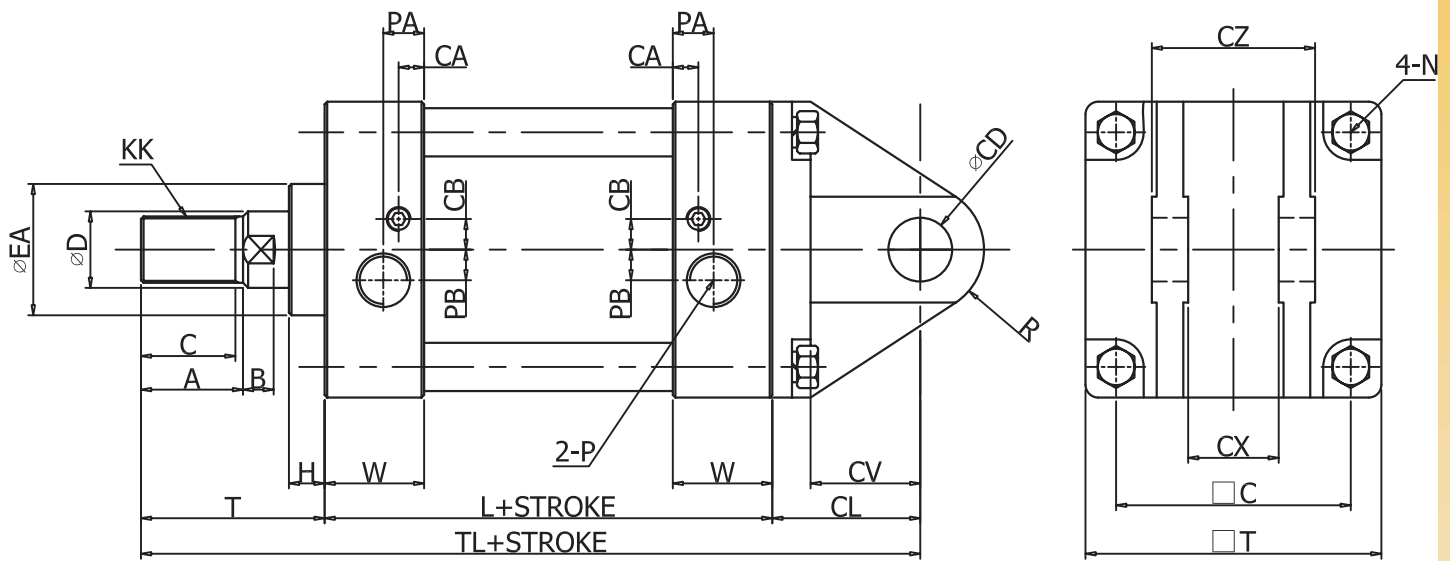

ID(mm)	Stroke Range	C	A	B	□C	ØD	P(PT)	ØEA	H	KK
40	~500	27	30	8	44	16	1/4	31.5	10	M14X1.5
50	~600	32	35	10	52	20	3/8	39.5	10	M18X1.5
63	~600	32	35	10	64	20	3/8	39.5	10	M18X1.5
80	~800	37	40	12	78	25	1/2	51.5	14	M22X1.5
100	~800	37	40	12	92	30	1/2	51.5	14	M26X1.5

ID(mm)	N	L	ΦCD	CL	CV	CX	CZ	R	□T	T	TL	W
40	M8X1.25	84	10 ^{+0.055} ₀	30	18	15 ^{-0.1} _{-0.3}	29.5	10	61	51	165	26
50	M8X1.25	90	12 ^{+0.070} ₀	35	23	12 ^{-0.1} _{-0.3}	38	12	70	58	183	27.5
63	M8X1.25	97.5	16 ^{+0.070} ₀	40	27	16 ^{-0.1} _{-0.3}	49	16	83	58	195.5	29.5
80	M12X1.75	115.5	20 ^{+0.085} ₀	48	34	20 ^{-0.1} _{-0.3}	61	20	102	71	234.5	36
100	M12X1.75	125.5	25 ^{+0.085} ₀	58	43	25 ^{-0.1} _{-0.3}	64	25	116	72	255.5	39

TAN AIR

TPCA2 J.I.S TYPE CYLINDER

T TYPE TRUNION

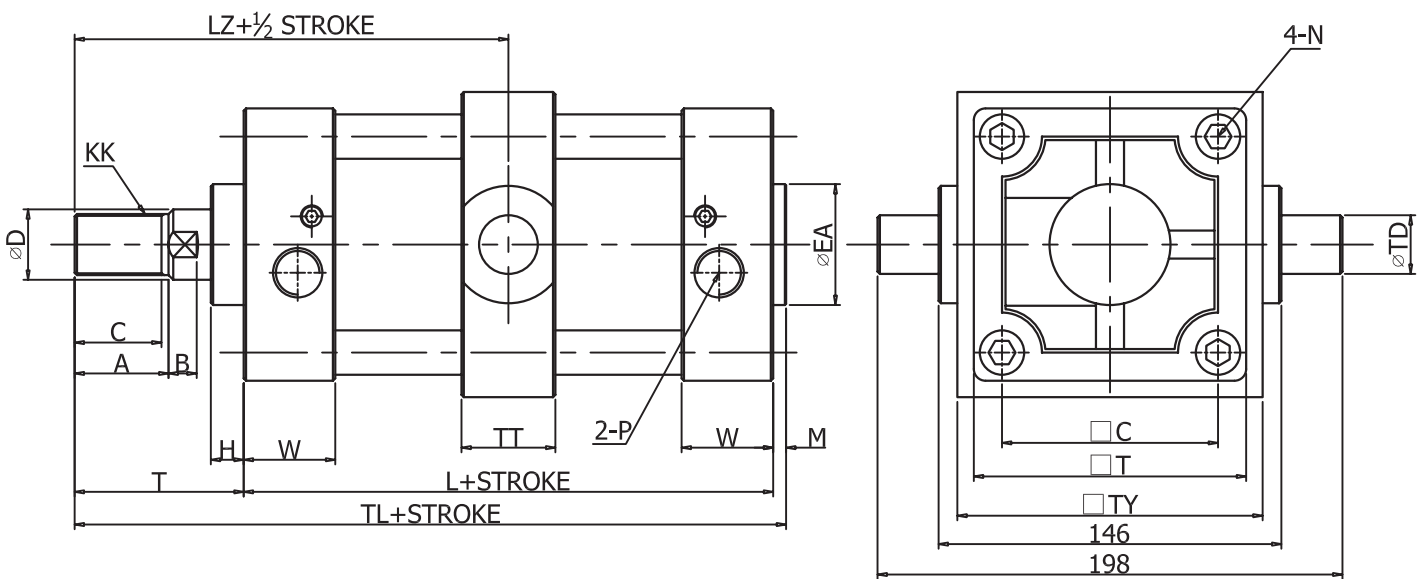

ID(mm)	Stroke Range	C	A	B	□C	ØD	P(PT)	ØEA	L	H	KK
40	~500	27	30	8	44	16	1/4	31.5	84	10	M14X1.5
50	~600	32	35	10	52	20	3/8	39.5	90	10	M18X1.5
63	~600	32	35	10	64	20	3/8	39.5	97.5	10	M18X1.5
80	~800	37	40	12	78	25	1/2	51.5	115.5	14	M22X1.5
100	~800	37	40	12	92	30	1/2	51.5	125.5	14	M26X1.5

ID(mm)	N	ΦTD	TT	TX	□TY	TZ	LZ	□T	T	TL	M	W
40	M8X1.25	15 ^{-0.040} _{-0.075}	22	85	62	117	93	61	51	140.5	5.5	26
50	M8X1.25	15 ^{-0.040} _{-0.075}	22	95	74	127	103	70	58	158.5	5.5	27.5
63	M8X1.25	18 ^{-0.040} _{-0.075}	28	110	90	148	107	83	58	161	5.5	29.5
80	M12X1.75	25 ^{-0.040} _{-0.075}	34	140	110	192	129	102	71	192	5.5	36
100	M12X1.75	25 ^{-0.040} _{-0.075}	40	162	130	214	135	116	72	203	5.5	39

TAN AIR

TPCA2 J.I.S TYPE CYLINDER

I TYPE SINGLE KNUCKLE JOINT

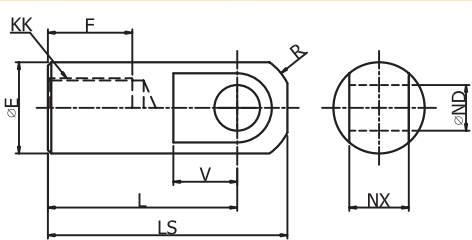

ID	KK	L	ØE	F	ØND	NX	R	LS	V
40	M14X1.5	55	24	22	12 ^{+0.07} ₀	16 ^{-0.1} _{-0.3}	15.5	69	20
50,63	M18X1.5	60	28	27	12 ^{+0.07} ₀	16 ^{-0.1} _{-0.3}	15.5	74	20
80	M22X1.5	71	36	37	18 ^{+0.07} ₀	28 ^{-0.1} _{-0.3}	22.5	91	26
100	M26X1.5	83	40	37	20 ^{+0.07} ₀	30 ^{-0.1} _{-0.3}	24.5	105	28

Y TYPE DOUBLE KNUCKLE JOINT

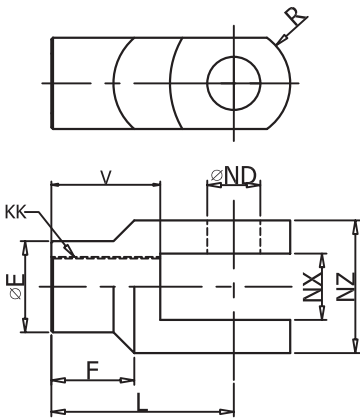

ID	KK	L	ØE	F	ØND	NX	NZ	R	V
40	M14X1.5	55	24	22	12 ^{+0.07} ₀	16 ^{+0.3} _{+0.1}	38	13	30
50,63	M18X1.5	60	28	27	12 ^{+0.07} ₀	16 ^{+0.3} _{+0.1}	38	15	33
80	M22X1.5	71	36	37	18 ^{+0.07} ₀	28 ^{+0.3} _{+0.1}	55	19	43
100	M26X1.5	83	40	37	20 ^{+0.07} ₀	30 ^{+0.3} _{+0.1}	61	21	45

RN TYPE ROD NUT

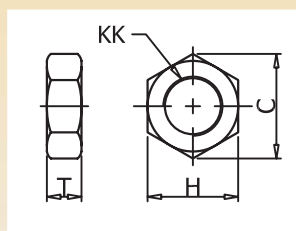

ID	KK	C	H	T
40	M14X1.5	25.4	22	8
50,63	M18X1.5	31.4	27	11
80	M22X1.5	37	32	13
100	M26X1.5	47.3	41	16

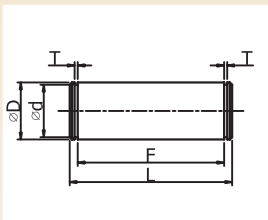

PIN FOR CLEVIS

ID	ØD	Ød	L	F	T
40	10 ^{-0.04} _{-0.06}	9	35.8	29.7	1.15
50	12 ^{-0.04} _{-0.06}	11	44.3	38.2	1.15
63	16 ^{-0.05} _{-0.08}	14.5	55.3	49.2	1.15
80	20 ^{-0.08} _{-0.11}	18.5	68.2	61.2	1.35
100	25 ^{-0.08} _{-0.11}	23	71.2	64.2	1.35

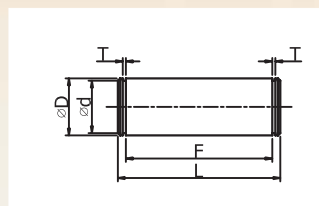

KUNCKLE JOINT PIN

ID	ØD	Ød	L	F	T
40,50,63	12 ^{-0.05} _{-0.08}	11	44.3	38.2	1.15
80	18 ^{-0.05} _{-0.08}	16.5	62.2	55.2	1.35
100	20 ^{-0.08} _{-0.11}	18.5	68.2	61.2	1.35