

TAN AIR

TPCA2 J.I.S TYPE CYLINDER THROUGH ROD TYPE

Standard Stroke Table

BORE(mm)	Standard Strokes
40	25,50,75,100,125,150,175,200,250,300,350,400,450,500
50	25,50,75,100,125,150,175,200,250,300,350,400,450,500,600
63	25,50,75,100,125,150,175,200,250,300,350,400,450,500,600
80	25,50,75,100,125,150,175,200,250,300,350,400,450,500,600,700,800
100	25,50,75,100,125,150,175,200,250,300,350,400,450,500,600,700,800

SPECIFICATIONS

Type	Oiless Type	Low-hydraulic Type
Fluid	Air	Hydraulic working oil
Bearing Pressure	15kgf/cm ²	
Max Working Pressure	9.9kgf/cm ²	
Min Working Pressure	0.8kgf/cm ²	1.6kgf/cm ²
Working Piston Speed	50-500mm/s	0.5-300mm/s
Working Temp	5-60°C	
Cushion	Both-Sides	None
Screw Tolerance	Ks2 2nd KS Level	
Allowance of Stroke Length	~250 ^{+1.0} ₀	251~800 ^{+1.4} ₀
Mounted Type	Basic Type, Foot Type , Flange Type Center Truinion Type	

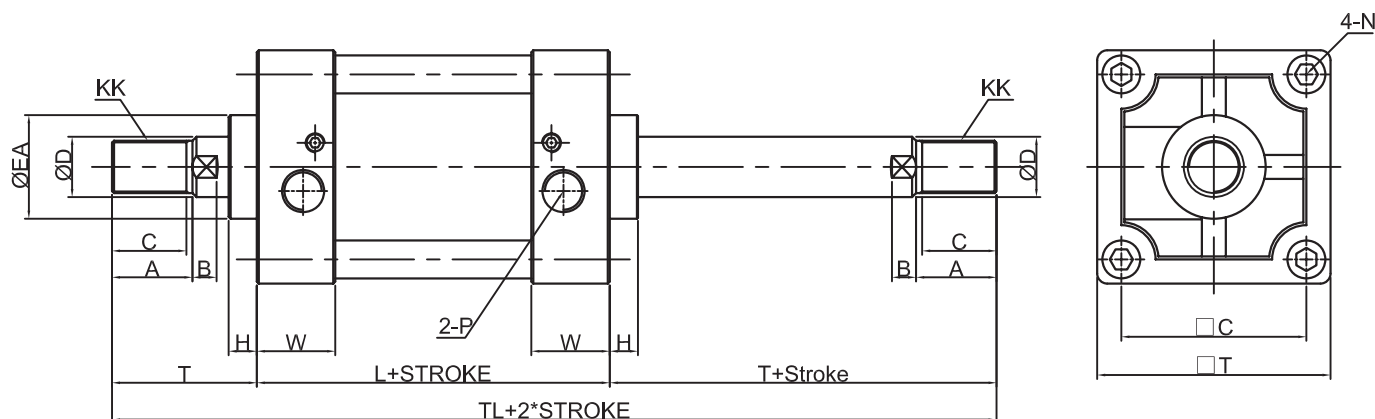

ID(mm)	Stroke Range	C	A	B	□C	ØD	P(PT)	ØEA	H	KK	L
40	~500	27	30	8	44	16	1/4	31.5	10	M14X1.5	84
50	~600	32	35	10	52	20	3/8	39.5	10	M18X1.5	90
63	~600	32	35	10	64	20	3/8	39.5	10	M18X1.5	97.5
80	~800	37	40	12	78	25	1/2	51.5	14	M22X1.5	115.5
100	~800	37	40	12	92	30	1/2	51.5	14	M26X1.5	125.5

ID(mm)	N	□T	T	TL	W
40	M8X1.25	61	51	140.5	26
50	M8X1.25	70	58	158.5	27.5
63	M8X1.25	83	58	161	29.5
80	M12X1.75	102	71	192	36
100	M12X1.75	116	72	203	39

TANAIR

TPCA2 J.I.S TYPE CYLINDER DUST BOOT TYPE

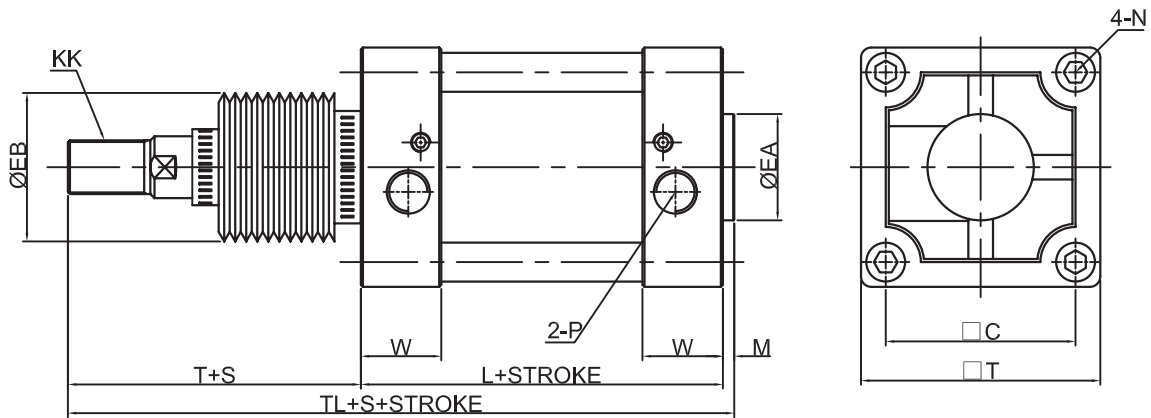

ID(mm)	Stroke Range	□C	□T	P(PT)	ØEA	L	ØEB	KK	T	TL	M
40	20~500	44	61	1/4	31.5	84	43	M14X1.5	51	148.5	5.5
50	20~600	52	70	3/8	39.5	90	52	M18X1.5	58	161.5	5.5
63	20~600	64	83	3/8	39.5	97.5	52	M18X1.5	58	169	5.5
80	20~800	78	102	1/2	51.5	115.5	55	M22X1.5	71	201	5.5
100	20~800	92	116	1/2	51.5	125.5	65	M26X1.5	72	212	5.5

ID(mm)	N	W	S
40	M8X1.25	26	
50	M8X1.25	27.5	
63	M8X1.25	29.5	
80	M12X1.75	36	
100	M12X1.75	39	

TAN AIR

TPCA2 J.I.S TYPE CYLINDER

MULTIPLE-END STROKE DOUBLE END-ROD TYPE TW

Notation

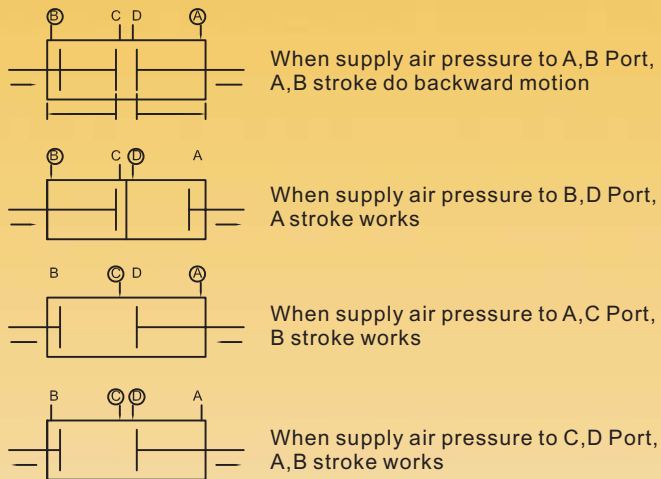

SPECIFICATIONS

Type	Oiless Type
Fluid	Air
Bearing Pressure	15kgf/cm ²
Max Working Pressure	9.9kgf/cm ²
Min Working Pressure	0.5kgf/cm ²
Working Piston Speed	50-500mm/s
Working Type	Double-Acting
Cushion	Cushion
Mounted Type	Basic Type, Foot Type of shaft direction Flange Type

OUTSIDE DIMENSION DRAWINGS / BASIC TYPE

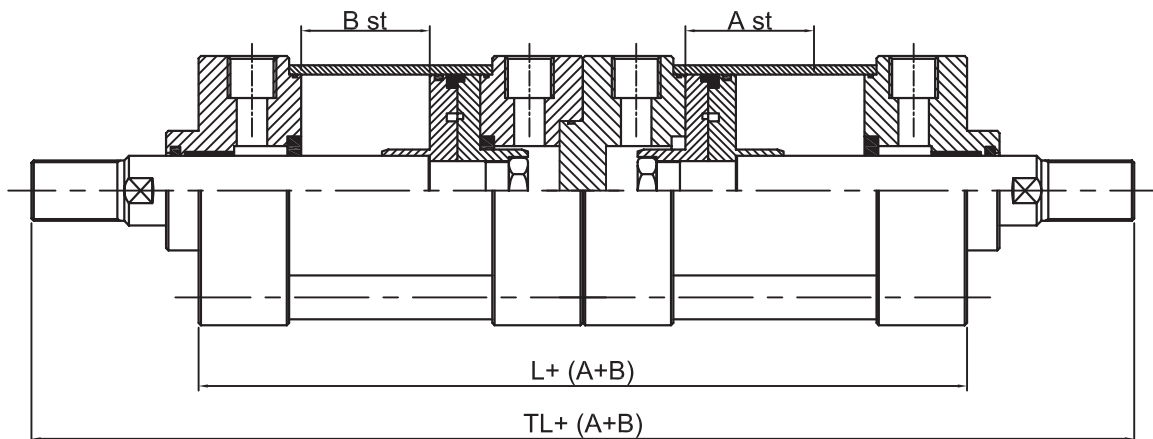

ID(mm)	L	TL
40	168	270
50	180	296
63	195	311
80	231	373
100	251	395

TANAIR

TPCA2 J.I.S TYPE CYLINDER

MULTIPLE-END STROKE SINGLE-ROD TYPE TS

Notation

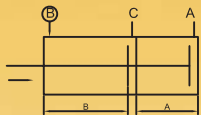

When supply air pressure to B Port,
A,B stroke do backward motion

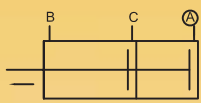

When supply air pressure to A Port,
A stroke works

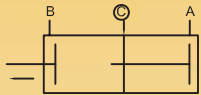

When supply air pressure to C Port,
B-A stroke works

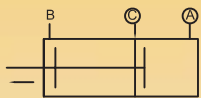

When supply air pressure to A,C Port,
A stroke works

SPECIFICATIONS

Type	Oiless Type
Fluid	Air
Bearing Pressure	15kgf/cm ²
Max Working Pressure	9.9kgf/cm ²
Min Working Pressure	0.5kgf/cm ²
Working Piston Speed	50-500mm/s
Working Type	Double-Acting
Cushion	Cushion
Mounted Type	Basic Type, Foot Type of shaft direction Rod-Side & Head-Side Flange Type, Single thread clevis type, Double thread clevis

OUTSIDE DIMENSION DRAWINGS / BASIC TYPE

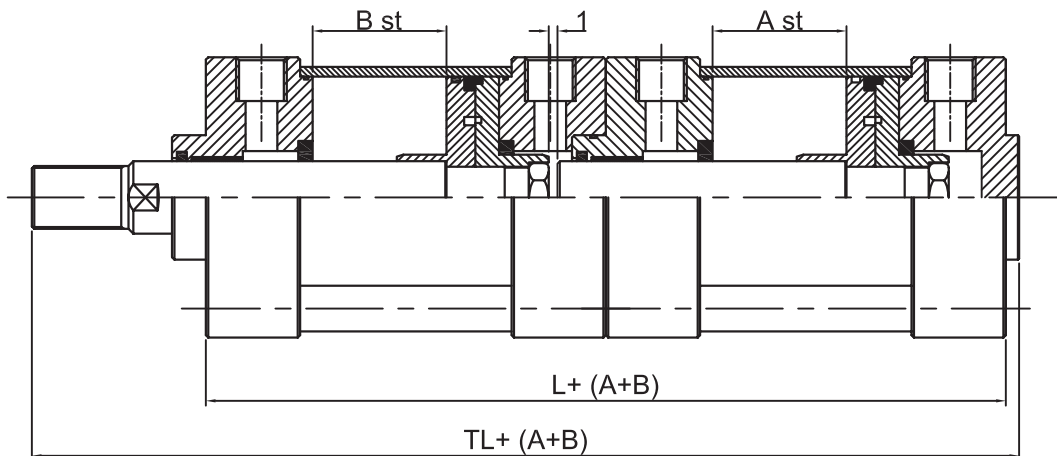

ID(mm)	L	TL
40	168	224.5
50	180	243.5
63	195	258.5
80	231	307.5
100	251	328.5

TANAIR

TPCA2 J.I.S TYPE CYLINDER VARIABLE STROKE CYLINDER TYPE/CONTROL TYPE OF FORWARDING MOTION SJ

SPECIFICATIONS

Type	OilessType	Low-Hydraulic Type
Fluid	Air	Hydraulic Working Oil
Bearing Pressure	15kgf/cm ²	
Max Working Pressure	9.9kgf/cm ²	
Min Working Pressure	0.5kgf/cm ²	1kgf/cm ²
Supporting type of Fitting Type	Basic Type, Foot Type, Rod-Side Flange Type	

NOTATION

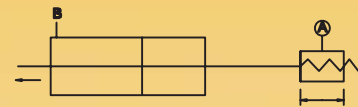

OUTSIDE STRUCTURE DIMENSION DRAWINGS / BASIC TYPE

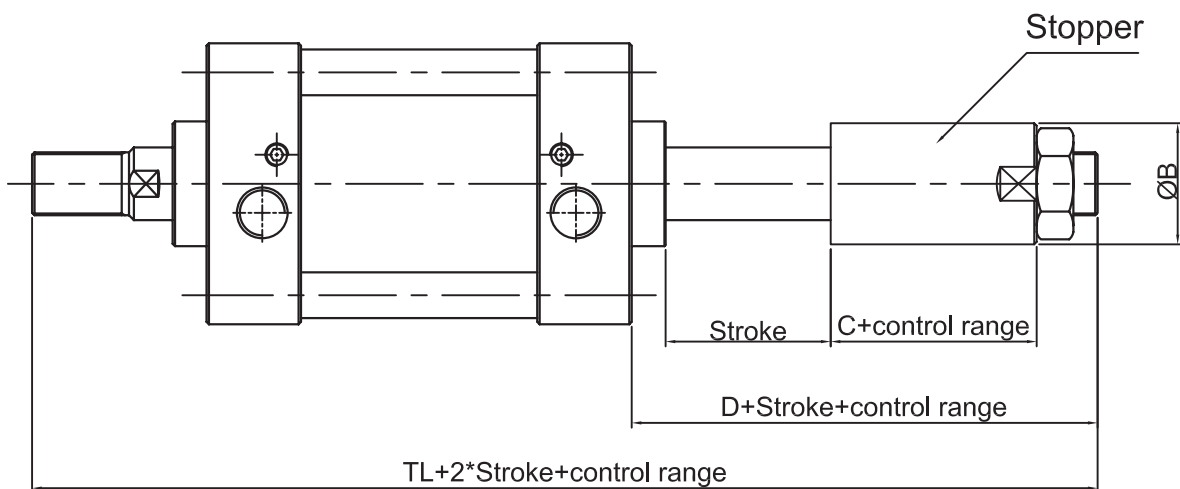

ID(mm)	ØB	C	D	TL
40	30	22	46	181
50	40	28	58	206
63	40	28	58	213.5
80	50	35	71	257.5
100	50	35	72	269.5

TANAIR

TPCA2 J.I.S TYPE CYLINDER

TANDEM CYLINDER / CYLINDER FOR HEAT RESIST

NOTATION



When supply air pressure to B and D Port, can get twice more outputs at backward motion

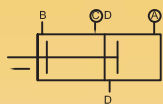

When supply air pressure to A and C Port, can get twice more outputs at forward motion

SPECIFICATIONS

Type	OilessType
Fluid	Air
Working Type	Double Acting
Max Working Pressure	9.9kgf/cm ²
Min Working Pressure	1kgf/cm ²
Cushion	Cushion
Working Piston Speed	50-500mm/s
Supporting type of Fitting Type	Basic Type, Foot Type, Rod-Side Flange Type, Head-Side Flange Type, Single thread Clevis Type, Double thread Clevis Type

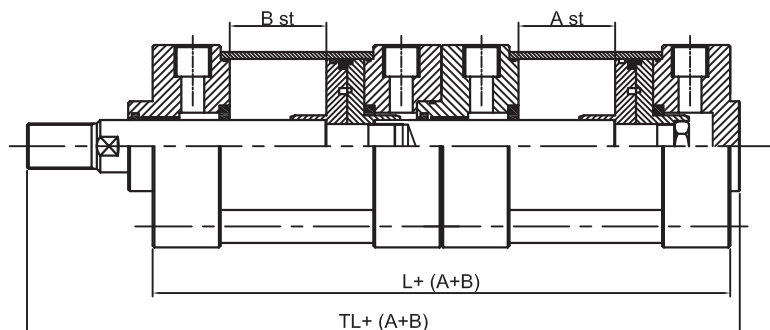

ID(mm)	L	TL
40	168	224.5
50	180	243.5
63	195	258.5
80	231	307.5
100	251	328.5

CYLINDER FOR HEAT RESIST

SPECIFICATIONS

Type	Oil Supply Type
Inside Diameter	40,50,63,80,100
Working Temp	-20°C~+150°C
Packing Material	VITON(Fluoric Rubber)

CYLINDER FOR HEAT RESIST

SPECIFICATIONS

Type	Oil Supply Type
Inside Diameter of Tube in cylinder	40,50,63,80,100
Material of Piston Rod Nut	Stainless Steel(SUS 304)